

# ISUPPLY STAINLESS STEEL HYDRANT VALVES

Premium Quality. Supreme Strength & Corrosion Resistance  
 Complies with AS/NZS 2419.2

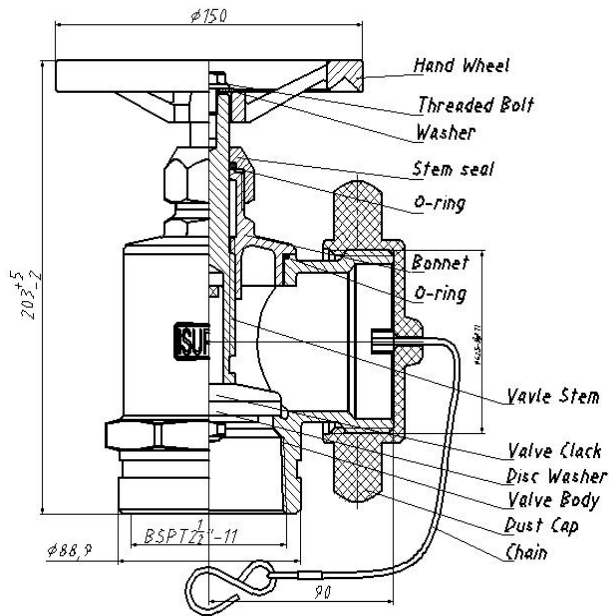

Stock Code	Thread Type	Inlet Type	Weight
ISP-HVFBT-SS	65mm NSW Male	65mm Male BSP	4.25 kg
ISP-HVFBTRG-SS	65mm NSW Male	80mm Roll Grooved	4.25 kg
ISP-HVQRT-SS	65mm QRT Male	65mm Male BSP	4.27 kg
ISP-HVQRTRG-SS	65mm QRT Male	80mm Roll Grooved	4.27 kg
ISP-HVDCFA-SS	65mm CFA Male	80mm Roll Grooved	4.35 kg
ISP-HVBIRG-SS	65mm BI	80mm Roll Grooved	5.60 kg
Material - Body		Stainless Steel Grade 304	
- Bonnet		Stainless Steel Grade 304	
- Stem		Stainless Steel Grade 316	
- Hand Wheel		C Steel	
- O-ring		NBR Rubber	
- Seal (Disc Washer)		NBR Rubber	
- Dust Cap		U-V Stabilized Plastic	
Working Pressure		1,400 kPa	
Test Pressure		2700 kPa	
Working Temperature		-10°C ~ 85°C	
Standard Approval		AS 2419.2	
WaterMark Cert. No.		CoC40189	

Distributed by:



# 1300 353 353